

CONTENTS

PRODUCT OVERVIEW	1	Redial.....	28
BEFORE YOU BEGIN	2	Display Dial.....	28
Parts List.....	2	Auto Redial.....	29
Tools Needed.....	2	Hold.....	30
Glossary.....	3	Switch Between Lines	
Audible Signals	4	During a Call.....	30
INSTALLATION	5	Mute	31
Battery Installation.....	5	Flash.....	31
Table/Desk Installation.....	6	Conference Calls	31
Wall Installation.....	9	Low Battery Indicator	32
Switchable Data Port.....	11	Lights and What They Mean	32
Headset Jack.....	11	ONE TOUCH OPERATION	33
MENU OPERATION	12	Store a Number in a One Touch	
Menu Structure	13	Location	34
Rapid Scroll.....	13	View a One Touch Entry	35
FEATURE SETUP	14	Dial a One Touch Number	36
Turn Auto Speaker On or Off	14	Erase a One Touch Number.....	36
Set a Primary Line	14	DIRECTORY OPERATION	37
Turn Automatic Line Selection		Menu Structure	37
On or Off.....	15	Store a Name and Number	
Set Preferred Mode	16	in the Directory.....	38
Set the Time and Date	17	Review Directory Entries.....	40
Turn Screen Backlight On or Off	18	Edit a Directory Entry.....	40
Set the Scroll Rate.....	18	Dial a Number from the	
Turn COVM Indicator On or Off		Directory	42
for Each Line.....	19	Remove a Name and Number	
Turn NEW CALL Light Off.....	20	from the Directory.....	42
Program Home and Local		CALLER ID	43
Area Codes.....	21	Caller ID Display.....	44
Set Call History.....	22	Call Waiting	45
Choose How to Store Repeat Calls		Display Screen Messages	45
in Call History.....	23	Message Waiting and	
Turn Caller ID with Call Waiting		NEW CALL Light.....	46
On or Off.....	24	Call History.....	46
Set the Display Language.....	24	Remove Calls from Call History....	48
TELEPHONE OPERATION	25	Dial a Number from Call History...49	
Make, Answer or End a Call.....	25	Save a Name and Number from	
Switch Between Handset, Headset		Call History to the Directory	50
and Speakerphone.....	26		
Timer	27		
Volume.....	27		

Save a Number from Call History
in a One Touch Location51

DEFAULT SETTINGS52

**GENERAL PRODUCT
CARE.....53**

**TECHNICAL
SPECIFICATIONS.....54**

IN CASE OF DIFFICULTY55

INDEX.....58

PRODUCT OVERVIEW

This AT&T Two-Line Speakerphone with Caller ID/Call Waiting 992 can be used with one or two incoming telephone lines and features a speakerphone for hands-free use. It is hearing-aid compatible and can also be used hands-free with a two-band 2.5 mm headset (purchased separately). This phone can be used on a desk or mounted on a wall and does not require AC power for basic operation when a fresh 9V alkaline battery is installed.

The 992 has a switchable data port for connecting the phone to another device such as a fax machine or modem. This phone has a Caller ID feature which supports Caller ID with Call Waiting service. (Caller ID services are subscriber services available from many local telephone companies for a fee.) The backlit screen display allows you to view information on the screen even in low light conditions. The 992 also features a 24-number memory for faster dialing and has a directory which can store up to 100 additional numbers with names.

This User's Manual contains detailed instructions for installing, programming and operating your AT&T Two-Line Speakerphone with Caller ID/Call Waiting 992. Please be sure to follow the directions carefully.

BEFORE YOU BEGIN

Parts List

Your box should include:



Tools Needed

You will also need the following to install your phone:

- 9V alkaline battery

Glossary

Caller ID: Caller Identification is a subscriber service available from most local telephone companies for a fee. When you subscribe to Caller Identification, you can see who's calling before you answer the phone if you and the caller are both in areas offering Caller ID service with compatible equipment.

Caller ID with Call Waiting: This is a single, combined subscriber service which may be available from your local telephone company. If you subscribe to this service, you can use your 992 telephone to see who's calling even while you are on another call (as long as your caller is in an area with Caller ID service and both telephone companies use compatible equipment).

COVM: Central Office Voice Mail is a subscriber voice message service which may be available from your local telephone company. This service may be called by another name in your area (e.g., Call Answering).

Home Area Code: This is the area code for your telephone number. Most users simply dial the seven digits of a phone number to make a call within their own area code and 11 digits outside of their area code. If this applies to you, enter your own area code into the unit as the Home Area Code. After programming, if you receive a call from within your Home Area Code, the screen will display the seven digits of the phone number.

You may, however, live in a region where for calls within your own area code, you must dial 10 digits (that is, the area code and phone number). If this applies to you, enter "000" for the Home Area Code and enter your area code as a Local Area Code. After programming, if you receive a call from within your area code, the screen displays the 10 digits of the phone number. Be sure to follow the directions under "Program Home and Local Area Codes" on page 21 during Feature Setup.

Local Area Code: Most users dial 11 digits to make calls outside their own area codes. If this applies to you, you do not need to program any Local Area Codes.

However, if you dial only 10 digits to make calls to some areas outside your own area code (without dialing "1"), then program these Local Area Codes into the phone. Up to four Local Area Codes can be programmed. After programming, if you receive a call from one of these Local Area Codes, the screen displays the 10 digits of the phone number. See "Program Home and Local Area Codes" on page 21 for instructions.

Navigation buttons: These are the buttons used when programming your 992 phone and for scrolling through feature options (**ENTER**), **▲**, **▼**, **▶**, **◀**).

Primary Line: This is the line on your phone you designate to be selected automatically when you lift the handset, press **SPEAKER**, or press **HEADSET**.

Audible Signals

WHEN YOU HEAR:	IT MEANS:
A long, low frequency buzz, repeating (error tone)	An error has occurred. Try the operation again.
Three, ascending tones (confirmation tone)	The operation was successful.
Three beeps	You have reached the minimum or maximum volume setting.

INSTALLATION

Battery Installation

Before using the telephone, install a 9V alkaline battery (not included). In case of a power failure, you will be able to use the phone normally if a fresh 9V alkaline battery is installed, but Caller ID, headset and speakerphone may not work properly. If AC power fails and there is no battery power, your volume control will remain at the last setting until AC power is restored. The LCD screen, ringer and lights will not work until AC power is restored. You will be able to make and receive calls using only the handset only on Line 1. This phone has a Memory Loss Protection feature and will store your Caller ID information, memory and programmed settings until power is restored.

When battery power is low, **Batt** shows on the display to alert you. Replace the battery promptly.



CAUTION: Always disconnect all cords before installing a new battery.

- 1 Remove the label covering the display screen.
- 2 Turn the telephone upside down.
- 3 You may want to remove the desk wedge for easier access to the battery cover. Push down on the tabs, and lift the wedge up and away from the phone.

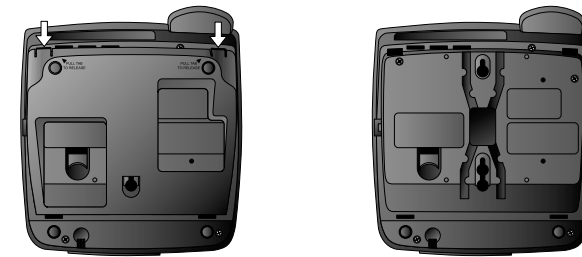

- 4 Press on the tab and pull to remove the battery cover. Insert one new 9V alkaline battery (not included) following the polarity markings in the battery compartment.

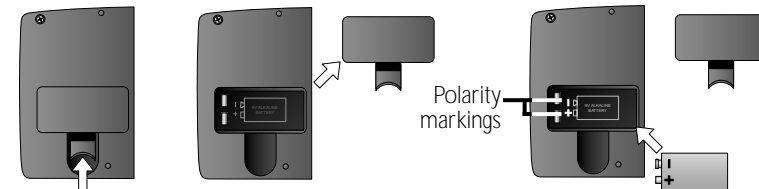

- 5 Replace the battery compartment cover.
- 6 If you are wall mounting the phone turn to "Wall Installation" beginning on page 9.

— OR —

If you are using your phone on a table or desk, turn to "Table/Desk Installation" beginning on page 6.

Table/Desk Installation

1 Attach the desk wedge.

If the desk wedge is not already attached, slide the tabs into the holes as shown. Snap the wedge onto the base.

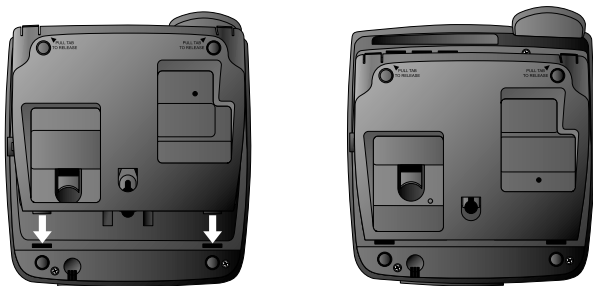

2 Connect the line cord(s) to the telephone and your modular wall jack(s).

- **If you have a single two-line wall jack**, use only the black (4-connector) line cord. Plug one end into the jack labeled **L1 OR L1/L2** on the back of the telephone. Plug the other end into the wall jack. Make sure the cord snaps firmly into place at both ends.

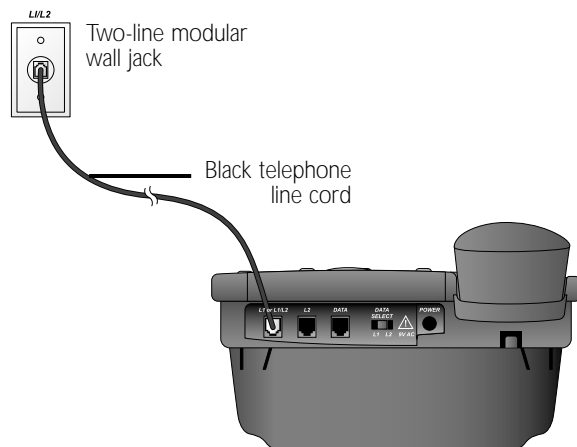

- **If you have two one-line wall jacks**, use both long line cords. For this installation option it does not matter which line cord you use for each line. Insert one end of the first cord into the jack labeled **L1 OR L1/L2** on the back of the phone. Then, plug the other end into the wall jack for Line 1. Insert one end of the other cord into the jack on the back of the phone labeled **L2**. Then, plug the other end into the wall jack for Line 2. Make sure the cords snap firmly into place at both ends.

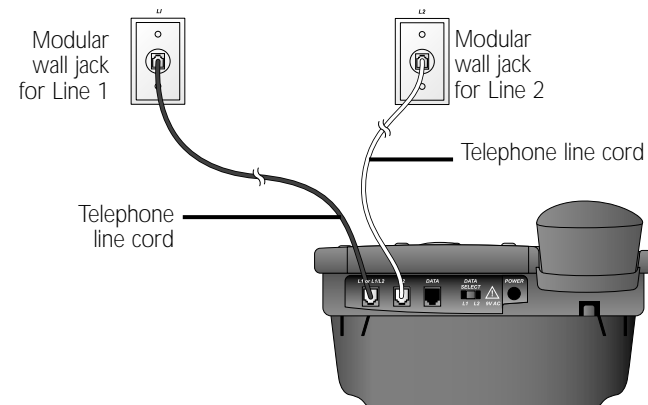

3 Connect the handset to the telephone.

Plug the coiled handset cord into the handset jack on the left side of the phone. Plug the other end of the coiled cord into the handset, then hang up.

continued on page 8

Table/Desk Installation

continued from page 7

4 Connect the power cord.

CAUTION: Use only the power cord supplied with this phone. If you need a replacement cord, call **1 800 222-3111**.

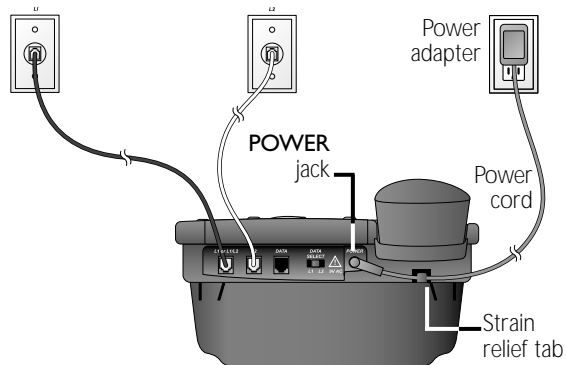

Fit the power cord behind the strain relief tab. Then plug the smaller end of the power cord into the jack labeled **POWER** on the back of the phone. Plug the power adapter into a standard electrical outlet not controlled by a wall switch.

5 Check for dial tone.

Press **LINE 1**, then lift the handset or press **SPEAKER** and listen for a dial tone. Then press **LINE 2** and listen for a dial tone. If you do not hear a dial tone, see **IN CASE OF DIFFICULTY** beginning on page 55.

6 Confirm Lines 1 and 2.

Press **LINE 1** and call one of your phone numbers. If you hear a busy signal, you called Line 1. If you hear a ringing signal in the receiver, then you called Line 2.

Wall Installation**1 Remove the desk wedge.**

If the desk wedge is attached, remove it following the directions in “Battery Installation” beginning on page 5. Store wedge in a safe place in case you use this phone on a table or desk in the future.

2 Reverse the handset tab.

Hold down the switchhook, and slide the tab up and out of its slot. Turn the tab so that the end with the “hook” is up, then insert the tab back into its slot.

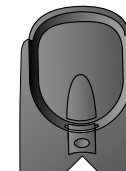

Figure 1



Figure 2

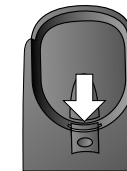
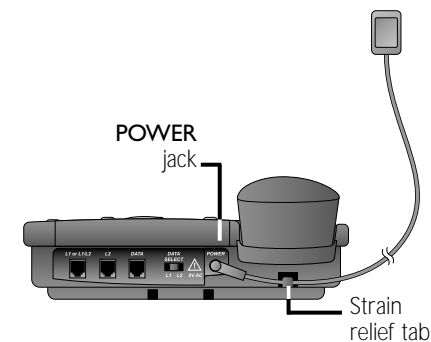

Figure 3

3 Connect the power cord to the phone.

Fit the power cord behind the strain relief tab. Then plug the smaller end of the power cord into the jack labeled **POWER** on the back of the phone.

**4 Connect the handset to the telephone.**

Plug the coiled handset cord into the handset jack on the left side of the phone. Plug the other end of the coiled cord into the handset, then hang up.

continued on page 10

Wall Installation

continued from page 9

5 Connect the line cord(s) to the telephone and your modular wall jack(s).

- **If you have a single two-line wall jack**, use only the short line cord. Plug one end into the jack labeled **L1 OR L1/L2** on the back of the telephone. Place the cord in the channel under the phone as shown. Plug the other end into the wall jack. Make sure the cord snaps firmly into place. Then, place the phone on the wall jack mounting studs and pull down until it is held securely.

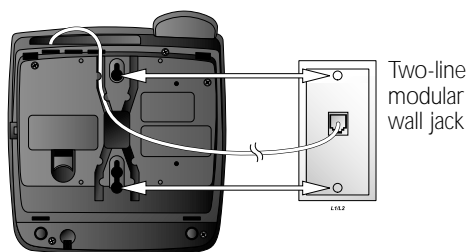

- **If you have two separate one-line wall jacks**, use two line cords (the short cord and one of the long cords). Plug one end of the short cord into the jack labeled **L1 OR L1/L2** on the back of the telephone. Plug one end of a long cord into the jack labeled **L2** on the back of the phone. Place the cords in the channels under the phone as shown. Plug the free end of the line cord for Line 1 into the Line 1 wall jack. Plug the free end of the line cord for Line 2 into the Line 2 wall jack. Make sure the cords snap firmly into place at both ends. Then, place the phone on the Line 1 wall jack mounting studs and pull until it is held securely.

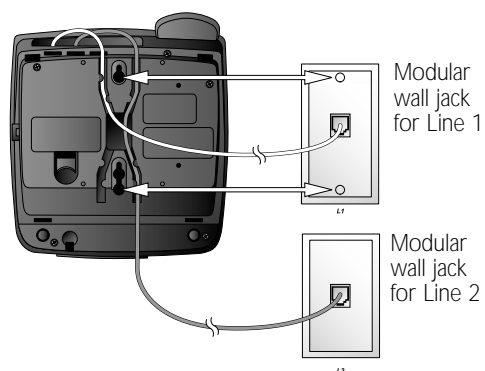

- 6 **Plug the power adapter into an AC outlet not controlled by a wall switch.**
- 7 **Follow Steps 5 and 6 in “Table/Desk Installation” on page 8.**

Switchable Data Port

If you want to connect another device (such as a modem or fax machine) to the wall jack, you can use the jack labeled **DATA** on the phone. You can set the data port to use Line 1 or 2. Set the **DATA SELECT** switch located on the back of the phone to **L1** or **L2**. A call picked up at another extension on the line used by the data port may interrupt a fax, modem or message transmission.

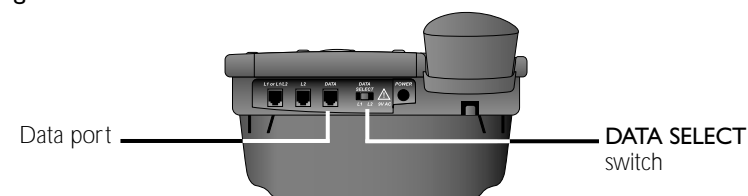
**Headset Jack**

- **NOTE:** A 9V alkaline battery **MUST** be installed for the headset to work correctly in all conditions.

You can use this phone hands-free when you install any AT&T two-band 2.5 mm headset, or other compatible, electronically isolated headset. Headsets must be purchased separately and are available by calling Customer Service at **1 800 222-3111**. For best results use an AT&T two-band 2.5 mm headset.

Make sure the headset is firmly plugged into the headset jack under the rubber flap on the right side of the phone. You will hear an error tone if you press **HEADSET** when the headset is not plugged in.

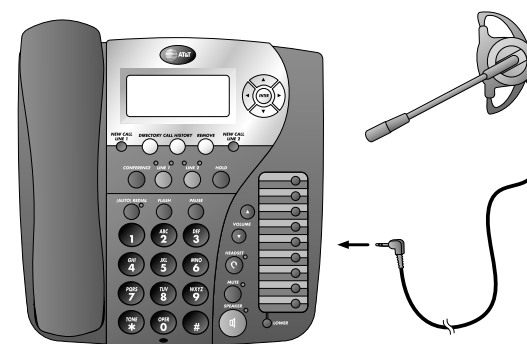

MENU OPERATION

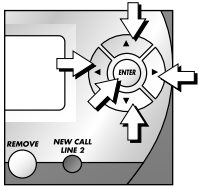

Feature setup, memory programming and some individual feature operations for the 992 use menus shown in the screen display. Use the navigation buttons (◀, ▶, ▲, ▼, **ENTER**) to begin, end and move through menu operations (for example, FEATURE SETUP).

- Press **ENTER** to activate a menu operation. The first menu item for this topic or data will appear in line four of the screen. For example, the screen displays:

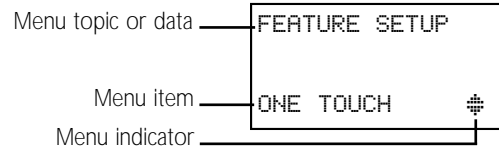

NOTE: If you do not press a key to continue menu operations within approximately 30 seconds, the telephone automatically exits the menu.

- When # is displayed on screen, you can press ▼ or ▲ repeatedly to move through the menu.
- Press **ENTER** to choose the menu item currently displayed. This may be a lower level menu, an action, or a feature settings screen. For example:

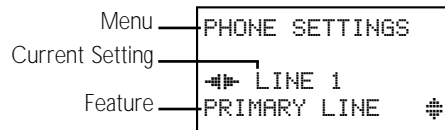

- When # is displayed on screen, you can press ▶ or ◀ to scroll through setting choices.
- Press ▼ or **ENTER** to store the setting and show the next option for the feature currently displayed. When you successfully change a setting, you will hear a confirmation tone.
- To return to the main menu, press ▼ or ▲ until the screen display includes MAIN MENU. Then press **ENTER**.
- To exit Feature Setup, press and hold **ENTER**.

NOTE: If you hear an error tone, repeat the steps to program the feature.

Menu Structure

Use the menu to set the values for the 992 features. Access the menu by pressing **ENTER** when the phone is idle. The menu for Feature Setup is below.

ONE TOUCH	VOICE MESSAGE
PROGRAM	L1 COVM ON/OFF
VIEW	L2 COVM ON/OFF
AUTO SPEAKER	L1 LIGHT OFF
MAIN MENU	L2 LIGHT OFF
PHONE SETTINGS	MAIN MENU
PRIMARY LINE	CALLER ID
ALS ON/OFF	AREA CODES
PREFERRED MODE	CALL HISTORY
SET TIME/DATE	REPEAT CALLS
LCD BACKLIGHT	CID-CALL WAIT
SCROLL RATE	MAIN MENU
MAIN MENU	LANGUAGE

Rapid Scroll

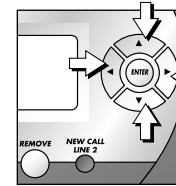

You can scroll through menu items or setting choices more quickly using this feature. Press and hold the desired scroll button (▲, ▼, ▶ or ◀). The screen will scroll through your choices at the rate you program during Feature Setup. See "Set the Scroll Rate" on page 18 for programming instructions.

FEATURE SETUP

Turn Auto Speaker On or Off

Choose whether pressing a One Touch button while the phone is on hook automatically initiates a One Touch call or displays the One Touch number without dialing the call. If you want to automatically dial the One Touch numbers by pressing a One Touch button without taking the phone off hook first, set Auto Speaker to ON. If you want to view One Touch numbers on screen by pressing a One Touch button while the phone is on hook, set Auto Speaker to OFF. This phone comes with Auto Speaker set to OFF. See ONE TOUCH OPERATION beginning on page 33 for details about One Touch calls.

NOTE: Auto Speaker dials the call in your selected Preferred Mode (see page 16). If the headset is not connected, the call is dialed using the speakerphone.

- 1 Press **ENTER** to begin feature setup.
- 2 Press **ENTER** again. The screen display includes ONE TOUCH and PROGRAM.
- 3 Press **▼** until the screen display includes AUTO SPEAKER and the current setting.
- 4 Press **◀** or **▶** to toggle between OFF and ON.
- 5 When the desired setting is shown, press **▼** or **ENTER** to save your choice. The screen display includes MAIN MENU.
- 6 Press and hold **ENTER** to return to the idle screen.

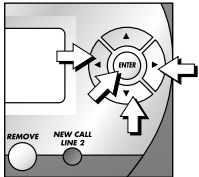

Set a Primary Line

- 1 Press **ENTER** to begin feature setup.
- 2 Press **▼** until the screen display includes PHONE SETTINGS.
- 3 Press **ENTER**. The screen display includes PRIMARY LINE and the current setting.
- 4 Press **◀** or **▶** to toggle between LINE 1 and LINE 2.
- 5 When the line you wish to set as primary is displayed, press **▼** or **ENTER** to save the setting. The screen display includes ALS ON/OFF.
- 6 Proceed to **Step 5** on page 15 to set the next feature (Automatic Line Selection).
— OR —
Press and hold **ENTER** to return to the idle screen.

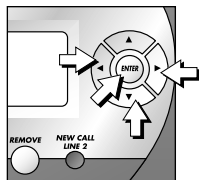

NOTE: When the phone is off-hook, the primary line setting is disabled.

Turn Automatic Line Selection On or Off

When this feature is turned on and you take the phone off hook, it automatically connects you to a pre-selected line. Lines have priority in this order: ringing primary, ringing non-primary, idle primary, idle non-primary, and busy primary.

Ringing primary: when the Primary Line is set to Line 1 and Line 1 is ringing, Line 1 is automatically connected.

Ringing non-primary: when the Primary Line is set to Line 1 and Line 1 is idle while Line 2 is ringing, Line 2 is automatically connected.

Idle primary: when the Primary Line is set to Line 1 and both lines are idle, Line 1 is automatically connected.

Idle non-primary: when the Primary Line is set to Line 1 and Line 1 is busy while Line 2 is idle, Line 2 is automatically connected.

Busy primary: when the Primary Line is set to Line 1 and Line 1 and Line 2 are busy, Line 1 is automatically connected.

- 1 Press **ENTER** to begin feature setup.
- 2 Press **▼** until the screen display includes PHONE SETTINGS.
- 3 Press **ENTER**. The screen display includes PRIMARY LINE.
- 4 Press **▼** until the screen display includes ALS ON/OFF and the current setting.
- 5 Press **◀** or **▶** to toggle between ON and OFF.
- 6 When the correct setting is shown, press **▼** or **ENTER** to save the setting. The screen display includes PREFERRED MODE.
- 7 Proceed to **Step 5** on page 16 to set the next feature (Preferred Mode).

— OR —

Press and hold **ENTER** to return to the idle screen.

NOTE: If you press a LINE button before pressing **SPEAKER**, that line will be used instead of the Automatic Line Selection you programmed. Automatic Line Selection will resume for the next call.

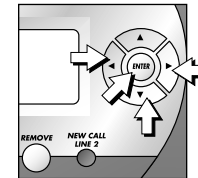

Set Preferred Mode

Choose the mode (headset or speakerphone) which will be used automatically when you dial a number from the directory, a One Touch location or call history without lifting the handset. The Preferred Mode will also be used when Auto Speaker is set to ON and you dial a One Touch number without lifting the handset. For information about the Auto Speaker setting, see “Turn Auto Speaker On or Off” on page 14.

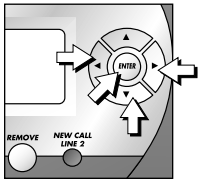

- 1 Press **ENTER** to begin feature setup.
 - 2 Press **▼** until the screen display includes PHONE SETTINGS.
 - 3 Press **ENTER**. The screen display includes PRIMARY LINE.
 - 4 Press **▼** until the screen display includes PREFERRED MODE and the current setting.
 - 5 Press **◀** or **▶** to toggle between Speakerphone and Headset.
 - 6 When the desired mode is displayed, press **▼** or **ENTER** to save the setting. The screen display includes SET TIME/DATE.
 - 7 Proceed to **Step 5** on page 17 to set the next feature (Time and Date).
- OR —
Press and hold **ENTER** to return to the idle screen.

Set the Time and Date

If you subscribe to Caller ID service, the time and date are set automatically with each incoming call. You can set the time and date manually following these instructions.

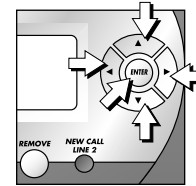

- 1 Press **ENTER** to begin feature setup.
 - 2 Press **▼** until the screen display includes PHONE SETTINGS.
 - 3 Press **ENTER**. The screen display includes PRIMARY LINE.
 - 4 Press **▼** until the screen display includes SET TIME/DATE.
 - 5 Press **ENTER**. The screen display includes Enter new time and the current setting.
 - 6 Use the dial pad keys to begin entering the correct time (hh/mm). The digits of the new time will appear on screen as you enter them.
 - 7 If needed, press **▲** or **▼** to toggle between AM and PM. Press **ENTER** when your choice is shown.
 - 8 When the correct time is shown, press **▲** or **▼** until the screen display includes DATE. Select DONE if the date is already correct.
 - 9 Press **ENTER** to save the time and move on to change the date. The screen display includes Enter new date and the current setting.
 - 10 Use the dial pad keys to begin entering the correct date (mm/dd). The digits of the new date appear on screen as you enter them.
 - 11 When the correct date is shown, press **ENTER** to save the setting. The screen display includes LCD BACKLIGHT.
 - 12 Proceed to **Step 5** in “Turn Screen Backlight On or Off” on page 18 to set the next feature (Screen Backlight).
- OR —
Press and hold **ENTER** to return to the idle screen.

NOTE: If you try to save an invalid time or date, you will hear an error tone and the date or time will not be changed.

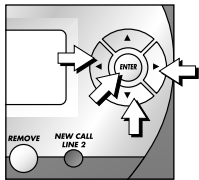

Turn Screen Backlight On or Off

- 1 Press **ENTER** to begin feature setup.
 - 2 Press **▼** until the screen display includes PHONE SETTINGS.
 - 3 Press **ENTER**. The screen display includes PRIMARY LINE.
 - 4 Press **▼** until the screen display includes LCD BACKLIGHT and the current setting.
 - 5 Press **◀** or **▶** to toggle between ON and OFF.
 - 6 When the correct setting is shown, press **▼** or **ENTER** to save your choice. The screen display includes SCROLL RATE.
 - 7 Proceed to **Step 5** in “Set the Scroll Rate” below to set the next feature (Scroll Rate).
- OR —
- Press and hold **ENTER** to return to the idle screen.

Set the Scroll Rate

You can choose the speed (scrolls per second) for the Rapid Scroll feature. (See “Rapid Scroll” on page 13 for details.)

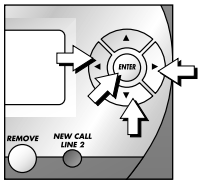

- 1 Press **ENTER** to begin feature setup.
 - 2 Press **▼** until the screen display includes PHONE SETTINGS.
 - 3 Press **ENTER**. The screen display includes PRIMARY LINE.
 - 4 Press **▼** until the screen display includes SCROLL RATE and the current setting.
 - 5 Press **◀** or **▶** to change the setting (Very Slow, Slow, Medium, Fast, or Very Fast).
 - 6 When the correct scroll rate is shown, press **▼** or **ENTER** to save the setting. The screen display includes MAIN MENU.
 - 7 Press **ENTER** to return to the main Feature Setup menu and continue setting up your phone.
- OR —
- Press and hold **ENTER** to return to the idle screen.

Turn COVM Indicator On or Off for Each Line

If you subscribe to Voice Mail service with your local telephone service provider, turn the COVM indicator on to have the NEW CALL light for that line flash when there are messages waiting. If you do not subscribe to Voice Mail service, turn the COVM indicators off for each line.

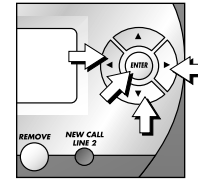

- 1 Press **ENTER** to begin feature setup.
 - 2 Press **▼** until the screen display includes VOICE MESSAGE.
 - 3 Press **ENTER**. The screen display includes L1 COVM ON/OFF and the current setting.
 - 4 Press **◀** or **▶** to toggle between OFF and ON for the line shown.
 - 5 Press **▼** to save the current setting and display the next line with its COVM setting.
 - 6 Repeat **Step 4** to turn the COVM indicator on or off for the other line.
 - 7 When you are finished setting the COVM indicators, press **▼** or **ENTER** to save the setting. The screen display includes L1 LIGHT OFF.
 - 8 Proceed to **Step 5** on page 20 to set the next feature (NEW CALL Light).
- OR —
- Press and hold **ENTER** to return to the idle screen.

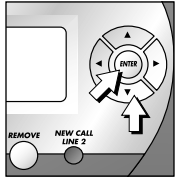

Turn NEW CALL Light Off

If a NEW CALL light continues to flash when there are no messages on that line, you may have received a false signal from your local telephone service provider. You can turn off the light manually.

- 1 Press **ENTER** to begin feature setup.
 - 2 Press **▼** until the screen display includes VOICE MESSAGE.
 - 3 Press **ENTER**. The screen display includes L1 COVM ON/OFF.
 - 4 Press **▼** until the screen display includes LIGHT OFF and the line number of the light you want to turn off.
 - 5 Press **ENTER** to turn the light off for that line. The screen display includes MAIN MENU.
 - 6 Press **ENTER** to return to the main Feature Setup menu and continue setting up your phone.
- OR —
- Press and hold **ENTER** to return to the idle screen.

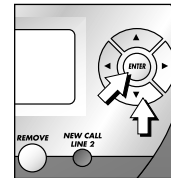

Program Home and Local Area Codes

You can program this phone to recognize one Home and up to four Local Area Codes. (See "Glossary" on page 3 for definitions.) The Home Area Code must be programmed in order for you to dial numbers in call history and so that you can transfer numbers from the call history to the directory. By programming these specific area codes, the unit will be able to distinguish a local call from a long distance call and will dial the appropriate number of digits.

NOTE: If you must dial the area code to place calls within your own area code, enter "000" for the Home Area Code and enter your area code as a Local Area Code.

- 1 Press **ENTER** to begin feature setup.
 - 2 Press **▼** until the screen display includes CALLER ID.
 - 3 Press **ENTER**. The screen display includes AREA CODES.
 - 4 Press **ENTER**. The screen display includes HOME and the current setting.
 - 5 Use the dial pad keys to enter your Home Area Code, then press **▼** to save the setting. The screen display includes LOCAL 1 and the current setting. If you need to enter any Local Area Codes, use the dial pad keys and then press **▼** to save your entry and scroll to the next Local Area Code (LOCAL 2, LOCAL 3, and LOCAL 4).
 - 6 When you are finished entering all of the area codes you need to program, press **▼** until the screen display includes DONE, then press **ENTER**. The screen display includes CALL HISTORY.
 - 7 Proceed to **Step 5** on page 22 to set the next feature (Call History).
- OR —
- Press and hold **ENTER** to return to the idle screen.

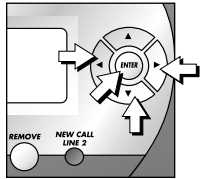

Set Call History

You can choose whether or not the phone stores calls in call history.

- 1 Press **ENTER** to begin feature setup.
 - 2 Press **▼** until the screen display includes CALLER ID.
 - 3 Press **ENTER**. The screen display includes AREA CODES.
 - 4 Press **▼** until the screen display includes CALL HISTORY and the current setting.
 - 5 Press **◀** or **▶** to toggle between All Calls and No Calls.
 - 6 When the correct setting is shown, press **▼** or **ENTER** to save your choice. You will hear a confirmation tone and the screen display includes REPEAT CALLS.
 - 7 Proceed to **Step 5** on page 23 to set the next feature (Repeat Calls).
- OR —
- Press and hold **ENTER** to return to the idle screen.

Choose How to Store Repeat Calls in Call History

You can choose how new calls from the same number are displayed. Choose Combined to show only the most recent call from the number. Set to Separate for the phone to display each call individually.

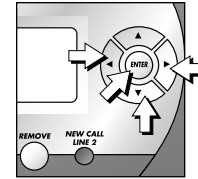

- 1 Press **ENTER** to begin feature setup.
 - 2 Press **▼** until the screen display includes CALLER ID.
 - 3 Press **ENTER**. The screen display includes AREA CODES.
 - 4 Press **▼** until the screen display includes REPEAT CALLS and the current setting.
 - 5 Press **◀** or **▶** to toggle between Combined and Separate.
 - 6 When the correct setting is shown, press **▼** or **ENTER** to save your choice. The screen display includes CID-CALL WAIT.
 - 7 Proceed to **Step 5** of “Turn Caller ID with Call Waiting On or Off” on page 24 to set the next feature (Caller ID with Call Waiting).
- OR —
- Press and hold **ENTER** to return to the idle screen.

Turn Caller ID with Call Waiting On or Off

If you subscribe to combined Caller ID with Call Waiting service from your local phone service provider, you need to turn this feature on in order to see call information for Call Waiting calls.

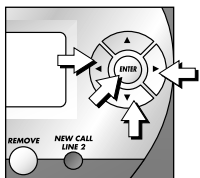

- 1 Press **ENTER** to begin feature setup.
- 2 Press **▼** until the screen display includes CALLER ID.
- 3 Press **ENTER**. The screen display includes AREA CODES.
- 4 Press **▼** until the screen display includes CID-CALL WAIT and the current setting.
- 5 Press **◀** or **▶** to toggle between ON and OFF.
- 6 When the correct setting is shown, press **▼** or **ENTER** to save your choice. The screen display includes MAIN MENU.
- 7 Press **ENTER** to return to the main Feature Setup menu and continue setting up your phone.
— OR —
Press and hold **ENTER** to return to the idle screen.

Set the Display Language

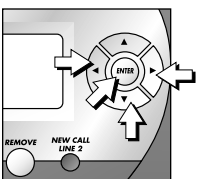

- 1 Press **ENTER** to begin feature setup.
- 2 Press **▼** until the screen display includes LANGUAGE and the current setting.
- 3 Press **◀** or **▶** to scroll through the language choices (English, Espanol, or Francais). When the language you want to use is displayed, press **▼** or **ENTER** to save the setting.
- 4 Press and hold **ENTER** to return to the idle screen.

TELEPHONE OPERATION

NOTE: When you make a call, the phone selects the Primary Line you programmed (See "Set a Primary Line" on page 14). When you answer a call, the phone automatically selects the ringing line.

Make, Answer or End a Call

NOTE: If the phone is in use on one line, any calls made or answered on the other line will use the same mode (handset, speakerphone, or headset) already in use.

NOTE: If you dial a phone number longer than 16 digits, the screen will display only the last 16 digits.

Handset

To make a call, lift the handset and dial the call. The number appears on screen as you dial.

To answer a call, lift the handset.

To override automatic line selection, lift the handset, then press and release a LINE button

— OR —

Press the LINE button for the line you wish to select, then lift the handset.

To end the call, replace the handset.

Speakerphone

To make a call, press **SPEAKER**. The SPEAKER light goes on. Wait for a dial tone, then dial the call. The number appears on screen as you dial.

To answer a call, press **SPEAKER** or press the LINE button of the incoming call, then press **SPEAKER**.

To override automatic line selection, press **SPEAKER**, then press and release a LINE button. Dial the call within five seconds.

— OR —

Press the LINE button for the line you wish to select, then press **SPEAKER**. Dial the call within five seconds.

To end a call, press **SPEAKER** again.

NOTE: If headset is programmed as the default mode (see "Set Preferred Mode" on page 16), you must press **SPEAKER** to activate the speakerphone.

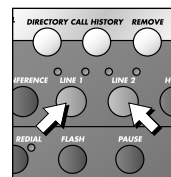

continued on page 26

Make, Answer or End a Call

continued from page 25

Headset

Make sure the headset is plugged into the headset jack. You will hear an error tone if you press **HEADSET** when the headset is not plugged in.

To make a call, press and release **HEADSET**. The HEADSET light goes on. Wait for a dial tone, then dial the call. The number appears on screen as you dial.

To answer a call, press **HEADSET**.

To override automatic line selection, press **HEADSET**, then press and release a LINE button. Dial the call within five seconds.

— OR —

Press the LINE button for the line you wish to select, then press **HEADSET**. Dial the call within five seconds.

To end a call, press **SPEAKER** again.

To end a call, press **HEADSET** again.

NOTE: If speakerphone is programmed as the default mode (See "Set Preferred Mode" on page 16), you must press **HEADSET** to activate the headset.

Switch Between Handset, Headset and Speakerphone

To switch from handset to headset or speakerphone, press **HEADSET** or **SPEAKER**, then replace the handset. (In order to use the headset, it must be firmly plugged in.)

To switch from speakerphone to handset, lift the handset. (Do not press **SPEAKER** or the call will be disconnected.)

To switch from headset to handset when the handset is in the cradle, lift the handset.

To switch from handset to headset when the handset is off-hook, press **HEADSET** again.

To switch from headset to speakerphone, press **SPEAKER**.

To switch from speakerphone to headset, insert the headset plug into the jack firmly, and press **HEADSET**.

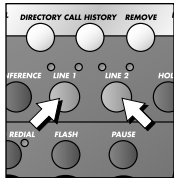
**Timer**

When you make or answer a call, the timer automatically starts. For outgoing calls the timer begins when you start to dial the number. The screen displays the elapsed time in minutes and seconds (up to 59:59) and then displays hours and minutes up to 10 hours (09:59) before starting at 00:00 again. The timer stops automatically when you hang up. When you place a call on hold, the timer remains in the screen display.

Volume Handset/Speakerphone/Headset Volume Control

When you are on a call, press VOLUME ▲ to increase call volume. Press VOLUME ▼ to decrease volume. The speakerphone has eight volume levels. The handset and headset have four levels. You will hear three beeps when you reach the minimum or maximum level.

**Ringer Volume**

You can adjust the ringer volume for each line independently. If a LINE button has been pressed, volume adjustments will affect the selected line. If no line is pre-selected, volume adjustments will affect the primary line you programmed (see "Set a Primary Line" on page 14). If one line is ringing, volume adjustments will affect the ringing line.

Press VOLUME ▲ or VOLUME ▼ to adjust the ringer volume. This phone has eight ringer volume levels, including off. Each time you adjust the ringer, you will hear a sample ring indicating the volume level.

Redial

The last number dialed on this phone (up to 24 digits) is stored in redial memory until you dial another number.

Handset

To dial the same number again, lift the handset, listen for the dial tone, then press **(AUTO) REDIAL**.

Speakerphone or Headset

To dial the same number again, press **(SPEAKER)** or **(HEADSET)**, then press **(AUTO) REDIAL**. The phone automatically dials the last number using the Primary Line you selected. (See “Set a Primary Line” on page 14.)

To dial the same number using a specific line, press **(SPEAKER)** or **(HEADSET)**, press a LINE button, then press **(AUTO) REDIAL**.

NOTE: You may experience a delay before the call is dialed when using the Redial feature. This is normal.

Display Dial

The Display Dial memory contains either the last incoming telephone number received on the phone, the last number reviewed in Call History, or the last number reviewed in the Directory, whichever was most recent. It is shown on line 4 of the display.

```
Redial:
9085550100
Display Dial:
908-5550100
```

Handset

To dial the Display Dial number, lift the handset, listen for the dial tone, then press **(ENTER)**.

Speakerphone or Headset

To dial the Display Dial number, press **(SPEAKER)** or **(HEADSET)**, then press **(ENTER)**.

To dial this number on a specific line, press **(SPEAKER)** or **(HEADSET)**, press a LINE button and then press **(ENTER)**.

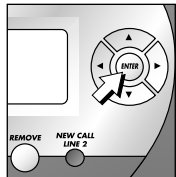
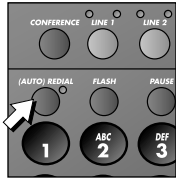

Auto Redial

The phone can automatically redial the last number you called up to ten times, until the other line rings or you cancel Auto Redial. Auto Redial calls are made using the speakerphone.

- While the phone is on hook, press **(AUTO) REDIAL**. The phone dials the number in redial memory using the Primary Line you selected or Automatic Line Selection if it is turned on. (See “Set a Primary Line” on page 14 or “Turn Automatic Line Selection On or Off” on page 15.)

— OR —

While the phone is on hook, press a LINE button to select a line. Then, press **(AUTO) REDIAL**. The phone dials the number in redial memory.

- When the other line rings or the other party answers, lift the handset

— OR —

Press **(SPEAKER)**

— OR —

Press **(HEADSET)** to speak with the other party.

If the number dialed is busy, the phone will disconnect, wait 40 seconds and redial the call up to 10 times.

To cancel Auto Redial at any time, press **(AUTO) REDIAL** again. Lifting the handset or pressing **(SPEAKER)** or **(HEADSET)** while the phone is redialing a call will also cancel the Auto Redial feature.

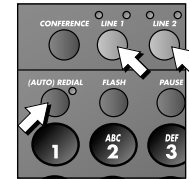

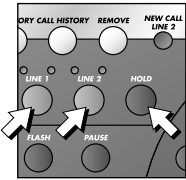

Hold

While on a call, press **HOLD**. The red LINE light for the call will flash slowly while the call is on hold. You can replace the handset in the cradle without disconnecting the call and the speakerphone or headset is automatically disabled.

To release hold and return to the call:

Press the LINE button for the call

— OR —

When Automatic Line Selection is set to OFF, you can lift the handset.

The call will automatically be reconnected in the original mode (speakerphone or headset), or you can lift the handset. The red LINE light for the call remains on steadily when you release Hold.

For information about Automatic Line Selection, see “Turn Automatic Line Selection On or Off” on page 15.

Switch Between Lines During a Call

During a call on one line, you can make or answer a call on the other line by pressing **HOLD**. You can use the **HOLD** and LINE buttons to switch back and forth between calls as often as necessary.

Example: While using Line 1, Line 2 rings:

- 1 Press **HOLD** to hold Line 1.
- 2 Press **LINE 2** to answer the other call.
- 3 Press **LINE 1** to hang up Line 2 and return to your first call

— OR —

Press **HOLD** to hold Line 2, and press **LINE 1** to return to your first call.

NOTE: If you switch lines without pressing **HOLD** first, you will drop the call.

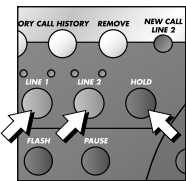

Mute

Mute allows you to hear the other party, but the other party can't hear you.

To activate this feature, press and release **MUTE**. The MUTE light goes on.

To return to the conversation, press and release **MUTE** again.

NOTE: Switching from handset to speakerphone or headset, or from speakerphone or headset to handset, changing lines, and putting a call on hold also cancel Mute.

Flash

Use **FLASH** instead of the switchhook to activate telephone company subscriber services such as Call Waiting or Three-Way Calling.

NOTE: During a conference call, flash works only on Line 1.

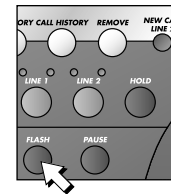

Conference Calls

You can use both lines at the same time to set up a three-way conference call.

- 1 Make or answer a call and press **HOLD**.
- 2 Establish a call on the other line.
- 3 Press **CONFERENCE**. All three parties are connected to the call.

To end a conference call, hang up.

If one caller hangs up during a conference call, you might hear a dial tone. Press the LINE button of the remaining call to disconnect the other line and eliminate the dial tone.

NOTE: Under certain circumstances, the far-end parties on a conference call may not hear one another clearly.

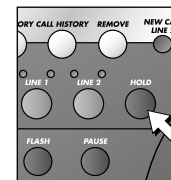
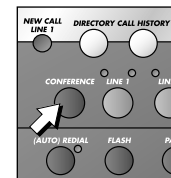

Place a Conference Call on Hold

- 1 Press **HOLD** to hold both lines.
- 2 Press **CONFERENCE** to release Hold and continue your conference call.

continued on page 32

Conference Calls

continued from page 31

Talk Privately With One Caller

- 1 Press **HOLD**.
- 2 Press the **LINE** button of the person with whom you want to speak privately.
- 3 Press **CONFERENCE** to continue your conference call.

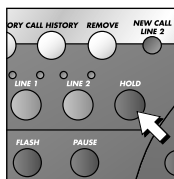
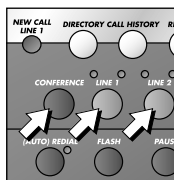

To disconnect one party from a conference call and keep the other on the line, press the **LINE** button of the call you want to continue.

Low Battery Indicator

The screen displays **Batt** when the battery needs to be replaced, or when no battery is installed.

Lights and What They Mean

LIGHT:	STATUS:	MEANS:
LINE, green	On steadily	This line is selected for use or is the designated primary line.
LINE, red	On steadily	This line is in use.
	Flashing slowly	This line is on hold.
	Flashing quickly	This line is ringing.
MUTE	On	This phone is muted.
SPEAKER	On	You are on a speakerphone call.
	Flashing	This phone is dialing an Auto Redial call. The microphone is not active.
HEADSET	On	You are on a headset call.
NEW CALL	On steadily	You have unreviewed call information on this line.
	Flashing	You have new voice mail messages waiting on this line.

ONE TOUCH OPERATION

This telephone has 18 One Touch locations where you can store phone numbers you wish to dial using fewer keys than usual. You can store up to 24 digits in each location.

The first nine locations can be accessed using only the One Touch buttons. To access the remaining nine locations, press **LOWER** and then the One Touch button for the desired location.

You may wish to write the names or telephone numbers of One Touch entries on the directory card, using the light gray spaces for the first nine locations and the dark gray spaces for the second nine locations.

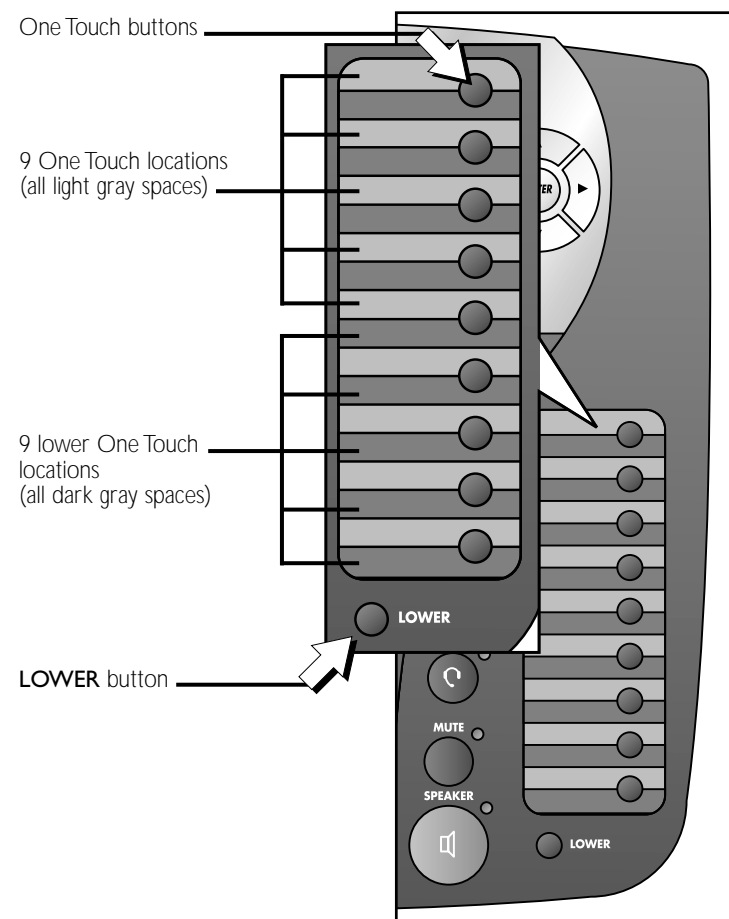

Store a Number in a One Touch Location

NOTE: You can store up to 24 digits in each One Touch location. If you try to store more than 24 digits, the screen will briefly display **Only 24 digits are allowed** and an error tone will sound.

- 1 Press **ENTER** to enter the feature menu. The screen display includes **ONE TOUCH**.
- 2 Press **ENTER**. The screen display includes **PROGRAM**.
- 3 Press **ENTER**. The cursor flashes on screen.
- 4 Enter the phone number using the dial pad keys — OR —
Press **(AUTO) REDIAL** to copy the last number dialed from this phone to this One Touch location. The screen will show the number as you enter it. The first 16 characters appear on the second line and the next eight on the third line. You can press **◀** to backspace and delete previous characters, or **▶** to move ahead and add one space. Each space counts as one digit and appears on screen as “—”.
- 5 When you are finished entering the number, choose a One Touch location:
Press the desired One Touch button. The screen displays the number you entered and **Has been stored**.
— OR —
Press **LOWER**, then press the desired One Touch button. The screen displays **LOWER MEMORY**, the number you entered, and **Has been stored**.

NOTE: You can exit storing a number any time. Press **▼** until the screen shows **EXIT PROGRAM**, then press **ENTER**.
— OR —
Press and hold **ENTER**.

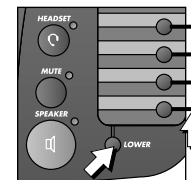
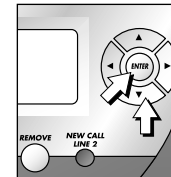
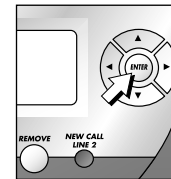
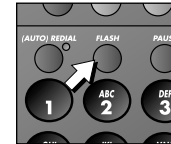
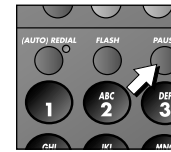
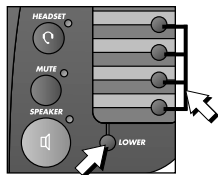
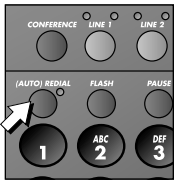
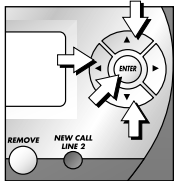

Store a Pause in a One Touch Entry

You can include a two-second pause while storing a dialing sequence which requires a pause during actual dialing.

When you want to enter a pause, press **PAUSE**. Each pause counts as one digit and appears on screen as **F**. Continue storing the number as usual.

Store a Flash in a One Touch Entry

You can store the flash signal required by some special services as part of a dialing sequence.

When you want to enter a flash signal, press **FLASH**. Each flash counts as one digit and appears on screen as **F**. Continue storing the number as usual.

Store a Wait in a One Touch Entry

You can include a 30-second wait while storing a dialing sequence which requires a break during actual dialing.

While you are entering the number to be stored, the screen display includes **WAIT**.

Press **ENTER** where you want to store the wait. Each wait counts as one digit and appears on screen as **W**. Continue storing the number as usual.

View a One Touch Entry

- 1 Press **ENTER** to enter the feature menu. The screen display includes **ONE TOUCH**.
- 2 Press **ENTER**. The screen display includes **PROGRAM**.
- 3 Press **▼** until the screen display includes **VIEW**.
- 4 Press **ENTER**. The screen displays **VIEW** on the top line.
- 5 Press the One Touch button. The screen display includes the number stored in that location.
—OR—
Press **LOWER**, then the One Touch button for the entry you want to review. The screen display includes **LOWER MEMORY** and the number stored in that location.
- 6 Press and hold **ENTER** to return to the idle screen.

If Auto Speaker is turned off (see “Turn Auto Speaker On or Off” on page 14), you can also view the number stored in a One Touch location while the phone is on hook by pressing the button(s) for the number you wish to view.

Dial a One Touch Number

NOTE: For more information about the Auto Speaker setting, see "Turn Auto Speaker On or Off" on page 14.

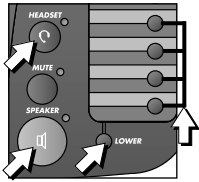

If Auto Speaker is turned on, calls will be dialed using the method you selected in "Set Preferred Mode" on page 16. If Preferred Mode is Headset but no headset is connected, the call will be dialed using the speakerphone.

Press and release a One Touch button

— OR —

Press and release **LOWER** then a One Touch button.

The phone dials the number automatically and the number is displayed on the screen.

If Auto Speaker is turned off, or you want to use the handset or headset regardless of Auto Speaker programming:

- 1 Lift the handset

— OR —

Press **SPEAKER**

— OR —

Press **HEADSET** and listen for dial tone.

- 2 Press and release a One Touch button

— OR —

Press and release **LOWER** then a One Touch button.

The phone dials the number automatically and the number is displayed on the screen.

NOTE: If there is a 30-second wait in the dialing sequence, you can press any dial pad key or One Touch button to end the wait and continue the dialing sequence.

Erase a One Touch Number

To remove a number from a One Touch location, enter another number in the same location.

To clear a One Touch location and leave it empty, follow the directions in "Store a Number in a One Touch Location" beginning on page 34, but do not enter a number. The screen display includes **NUMBER ERASED**.

DIRECTORY OPERATION

This phone can store up to 100 names and phone numbers in the directory. Names can be up to 16 characters long and numbers can be 24 digits long. Because directory entries are stored in alphabetical order, you may wish to enter names with the last name first in order to maintain consistency with the information stored automatically through the Caller ID function of this system.

To enter Directory mode, press **DIRECTORY**. The screen displays:

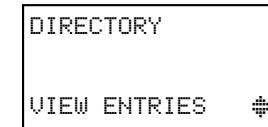
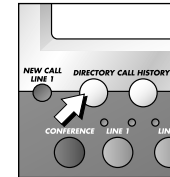

If there are already 100 stored entries, the screen display includes **DIRECTORY FULL!**. If there are no entries in the directory, the screen display includes **DIRECTORY EMPTY!**.

To exit Directory mode at any time, press **DIRECTORY** again.

Menu Structure

Use the navigation buttons (**←**, **→**, **▲**, **▼**, **ENTER**) to move through menu operations. See **MENU OPERATION** beginning on page 12 for information about moving through menus in the screen display. The menu structure for the directory is below.

```

VIEW ENTRIES
DIAL
  EDIT NAME
  DONE
  CANCEL
  EDIT NUMBER
  DONE
  WAIT
  CANCEL
  MAIN MENU
ADD ENTRY
  ENTER NUMBER
  DONE
  WAIT
  CANCEL
  
```

Store a Name and Number in the Directory

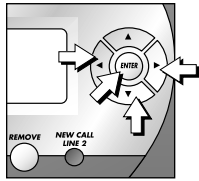
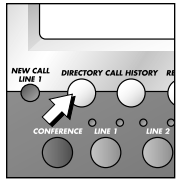

- 1 Press **DIRECTORY** to begin working with the directory.
- 2 Press **▼** until the screen display includes **ADD ENTRY**.
- 3 Press **ENTER**. The screen display includes **Enter name**.
- 4 Use the dial pad keys and the chart below to enter the letters, digits or symbols you wish to store. Press the key repeatedly until the character you want is shown on the screen. For example, press **2** once for "A," twice for "B," three times for "C," and four times for "2." When you want to enter two characters in a row which share a dial pad key (for example "M" and "O") you must press **▶** to move the cursor to the next position. Press **▶** to move or add a space. Press **◀** to backspace. The name will appear on screen as you enter it.

PRESS:	ONCE	TWICE	3 TIMES	4 TIMES	5 TIMES	6 TIMES	7 TIMES	8 TIMES
1	,	-	'	&	.	()	!
2	A	B	C	2				
3	D	E	F	3				
4	G	H	I	4				
5	J	K	L	5				
6	M	N	O	6				
7	P	Q	R	S	7			
8	T	U	V	8				
9	W	X	Y	Z	9			
*	*							
0	0							
#	#							

- 5 When you are finished entering the name, press **ENTER** to move on to enter the phone number. The screen displays the name you entered and **Enter number**.

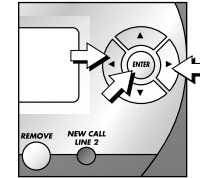
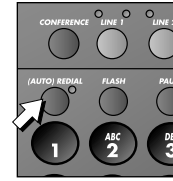

- 6 Use the dial pad keys to enter the phone number you wish to store

—OR—

Press **(AUTO) REDIAL** to copy the last number dialed at this extension onto the screen.

Press **▶** to move to the next character or space. Press **◀** to backspace. The number will appear on the second line of the screen as you enter it.

- 7 When you are finished entering the number, press **ENTER** to store the name and number in the directory. The screen briefly displays the name and number you stored and **SAVED!**. Then the screen will automatically return to include **ADD ENTRY**.

NOTE: To exit the directory at any time without storing the entry, simply press **DIRECTORY**. The screen will automatically return to the idle screen.

Store a Wait in a Directory Number

You can include a 30-second wait in a number stored in the directory. When you reach the place in the dialing sequence where you wish to enter a wait, press **▼** until the screen display includes **WAIT**. Then, press **ENTER** to store a 30-second wait, and continue entering the number. Each wait counts as one digit.

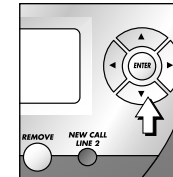

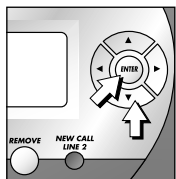
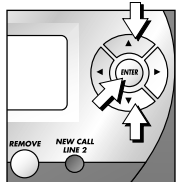
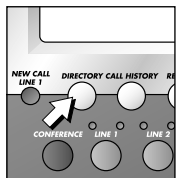

Review Directory Entries

- 1 Press **DIRECTORY** to begin working with the directory.
- 2 Press **ENTER**, then press **▲** or **▼** to scroll through the directory entries in alphabetical order

—OR—

Press the dial pad key for the first character of the entry you wish to review until the character you are looking for is displayed. Then press **▲** or **▼** to scroll through the entries beginning with this character. If there is no entry for the character you chose, the screen will display No Entries FOR "X".

—OR—

Press **ENTER**. The screen displays the first directory entry. Press **▲** or **▼** to scroll through the directory entries.

Edit a Directory Entry

Edit a Name in the Directory

- 1 Find the directory entry you wish to change by following the directions under "Review Directory Entries" above.
- 2 When the entry you want to edit is displayed, press **ENTER**. The screen display includes DIAL.
- 3 Press **▼** until the screen display includes EDIT NAME.
- 4 Press **ENTER** and start to edit the name using the dial pad keys. (See the instructions in **Step 4** of "Store a Name and Number in the Directory" beginning on page 38 for details.)
- 5 When you are finished editing the name, press **▼** until the screen display includes DONE.
- 6 Press **ENTER** to save the new name in the directory. The screen briefly displays the new entry and **SAVED!**. The screen automatically returns to the main directory menu.

NOTE: To exit the directory at any time without storing the entry, simply press **DIRECTORY**. The screen automatically returns to the idle screen.

Edit a Number in the Directory

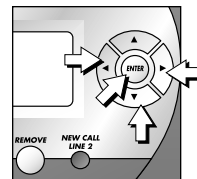

- 1 Find the directory entry you wish to change by following the directions under "Review Directory Entries" on page 40.
- 2 When the entry you want to edit is displayed, press **ENTER**. The screen display includes DIAL.
- 3 Press **▼** until the screen display includes EDIT NUMBER.
- 4 Press **ENTER** to begin editing the number using the dial pad keys. Press **◀** to backspace or **▶** to move to the next character or space. The number will appear on the second line of the screen as you enter it.
- 5 Press **ENTER** to store the new number in the directory. The screen display briefly shows the new entry and **SAVED!**. The screen automatically returns to the main directory menu.

NOTE: To exit the directory at any time without storing the entry, simply press **DIRECTORY**. The screen automatically returns to the idle screen.

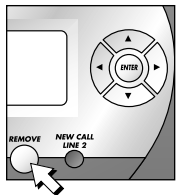
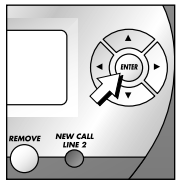

Dial a Number from the Directory

- 1 Press **DIRECTORY**.
- 2 Press **ENTER** and ▲ or ▼ to view entries.
- 3 Press **ENTER**. The screen display includes DIAL.
- 4 Press **ENTER** to dial the number on the screen.

The call is dialed in the mode (speakerphone or headset) you programmed (see “Set Preferred Mode” on page 16) using the Primary Line you programmed (see “Set Primary Line” on page 14).

— OR —

Lift the handset or press **SPEAKER** or **HEADSET**, then press **ENTER**. The phone automatically selects an idle line and dials the call.

— OR —

Press a **LINE** button to select a line, then press **ENTER**. The call is dialed in the mode (speakerphone or handset) you programmed (see “Set Preferred Mode” on page 16).

The screen displays the name and number while dialing.

Remove a Name and Number from the Directory

- 1 Find the entry for the number you wish to delete by following the directions under “Review Directory Entries” on page 40.
- 2 When the entry you wish to delete is displayed, press **REMOVE**. The screen briefly displays the directory entry and **REMOVED!**. Then, the screen automatically returns to the first directory entry.

CALLER ID

This telephone has a Caller ID feature that works with Caller Identification service provided by your local telephone company. There is a fee for this service, and it may not be available in all areas. This phone can provide information only if both you and the caller are in areas offering Caller Identification service, and if both telephone companies use compatible equipment.

When you use this phone with Caller ID service, you can see who's calling before you answer the phone. If you subscribe to Caller ID with Call Waiting, a **combined** service available through many local telephone companies, you can see who's trying to reach you even when you're on another call. This service may be called by different names (such as Caller ID with Visual Call Waiting) by different local telephone companies and may not be available in all areas.

NOTE: You must subscribe to **combined** Caller ID with Call Waiting as a single service to see Caller ID information for a Call Waiting call. Check with your telephone company for availability.

This phone assigns each incoming call a number from 1 to 99. The most recent call will have the highest number. (For example, if two calls have been received, call number 02 is the most recent.) When the call history is full, the oldest call information is automatically deleted to make room for new incoming call information.

The format of phone numbers displayed will depend on the Home and Local Area Codes you programmed. (See “Home Area Code” and “Local Area Codes” on page 3 for explanations of area codes. See “Program Home and Local Area Codes” on page 21 for programming instructions.) If the call came from within your Home Area Code, the screen displays only the seven digit number (without an area code). If the call came from one of your Local Area Codes, the screen displays 10 digits (area code plus the seven digit number). If the call did not come from any of the area codes you programmed, 1) phone numbers with 10 or more digits will automatically have a “1” inserted and displayed before the number and, 2) phone numbers with fewer than 10 digits will be displayed without a “1.”

Caller ID Display

When you receive a call, the screen first displays Waiting for caller information.

When Caller ID information becomes available, the screen display is similar to:

```
12:08 PM 12/26
SMITH, JOHN
5550123 L2
```

The time and date of the call, the caller's name and phone number are included in the display if sent by the caller's telephone company. The incoming line number of the call also appears on screen (L2 in the above example).

If two calls come in at the same time, the screen displays information about both calls:

```
SMITH, JOHN
5550123 L1
BROWN, MARY
5550127 L2
```

Other messages may appear on screen. See "Display Screen Messages" on page 45 for more information.

Caller ID information will remain on the screen for 30 seconds after the phone stops ringing or until you answer the call.

If you subscribe to Caller ID service, this phone automatically resets the time and date each time new call information is received. You can set the time and date yourself if you wish. (See "Set the Time and Date" on page 17.)

NOTE: If Caller ID information is received while you are programming the memory, the call information will be stored in call history without appearing on screen.

Call Waiting

If you subscribe to Caller ID with Call Waiting service and you receive a call waiting call, the screen displays call information for the call similar to:

```
12:08 PM 12/26
SMITH, JOHN
5550123 L2
00:01
```

- 1 Press **FLASH** to access the call waiting call.
- 2 To switch back to the original call, press **FLASH** again.

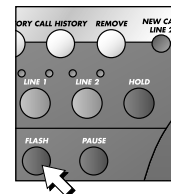

Display Screen Messages

DISPLAY:	MEANS:
PRIVATE NAME	The other party is blocking name information.
PRIVATE #	The other party is blocking telephone number information.
PRIVATE CALLER	The other party is blocking name and number information.
UNKNOWN NAME	This caller's name is unavailable.
UNKNOWN #	This caller's number is unavailable.
UNKNOWN CALLER	No call information is available about this caller.
ERROR	Call information cannot be recognized.

Message Waiting and NEW CALL Light

There is a NEW CALL light for each line. A NEW CALL light stays on when you have received call information for that line but have not yet reviewed it. If you subscribe to a Voice Mail service, a NEW CALL light flashes when you have unretrieved messages waiting on that line. The screen also displays information about the number of new calls for each line.

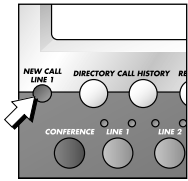
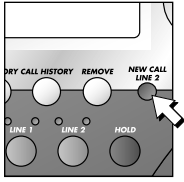

```
12:08 PM 12/26
L1: 22 New Calls
L2: 11 New Calls
```

Call History

View Call History Summary

- 1 Press **CALL HISTORY**. The screen displays the numbers of total calls and new calls in call history for each line:

```
CALL HISTORY
L1 15 CLS 10 New
L2 05 CLS 00 New
ALL LINES
```

- 2 Press **CALL HISTORY** again to exit Call History mode.

Review Records in Call History in the Order Received

- 1 While the phone is idle, press **▲** or **▼**
—OR—
Press **CALL HISTORY**, then press **ENTER**.

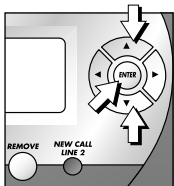

The screen displays the most recent caller's information:

```
10:27 AM 11/12
SMITH, JOHN
5550123 New
CL01 L2
```

10:27AM 11/12	Time and date of the call
L2	The call came in on Line 2
SMITH, JOHN	Caller's name
5550123	Caller's phone number
CL01	The call record number. (Call 01 is the oldest (first) record in call history.)
New	This is new, previously unreviewed call information.

See "Display Screen Messages" on page 45 for information about other possible messages.

- 2 Press **▲** or **▼** to scroll through the records in call history in the order they were received.

Review Records in Call History by Line

- 1 Press **CALL HISTORY**. The screen displays the numbers of total calls and new calls in call history:

```
CALL HISTORY
L1 15 CLS 10 New
L2 05 CLS 00 New
ALL LINES
```

- 2 Press **▲** or **▼** until the bottom line of the screen displays the line for the calls you want to review (LINE1 or LINE2). Then press **ENTER** to view the most recent caller's information for that line.
- 3 Press **▲** or **▼** to scroll through the records in call history for the selected line in the order they were received.

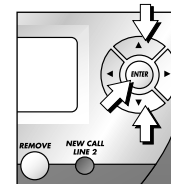
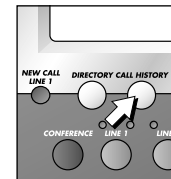

Remove Calls from Call History

Remove a Specific Call Record from Call History

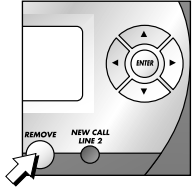

- 1 Locate the call record you wish to delete following the instructions under “Review Records in Call History in the Order Received” beginning on page 46.
- 2 Press **REMOVE**. The screen displays the next record in call history. If there are no records in call history, the screen displays Call History list is empty.

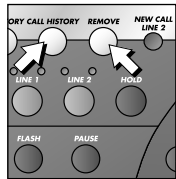

Remove All Calls from Call History

- 1 Press **CALL HISTORY**. The screen display is similar to:

```
CALL HISTORY
L1 15 CLS 10 New
L2 05 CLS 00 New
ALL LINES
```
- 2 Press **REMOVE**. The screen displays TO remove all calls, press REMOVE again.
- 3 Press **REMOVE** again within three seconds to confirm the command and delete all records from call history. The screen displays ALL calls have been removed. The screen automatically returns to the idle screen.

Dial a Number from Call History

As you review call history records you can dial a displayed phone number. If you have already entered home and local area codes, as discussed on page 21, the telephone numbers shown in the Call History will already be correctly displayed.

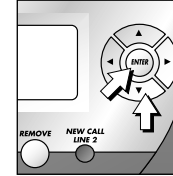

- 1 Locate the number you wish to call in call history (see “Call History” beginning on page 46).
- 2 Press **ENTER**. The screen display includes DIAL.
- 3 Press **ENTER**. The phone automatically selects an idle line and dials the displayed number.

—OR—

Lift the handset or press **SPEAKER** or **HEADSET**, then press **ENTER**. The phone automatically selects an idle line and dials the displayed number.

—OR—

Press the LINE button for the line you wish to use, then press **ENTER** to place the call.

The call is dialed in the preferred mode (speakerphone or headset) you programmed (see “Set Preferred Mode” on page 16).

NOTE: To exit without dialing the number, press **DOWN** until the display includes RETURN TO LIST, then press **ENTER**.

Dial Options

You can change the format of a number in call history before you dial.

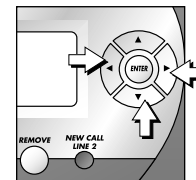

- 1 Follow the directions in **Steps 1 and 2** of “Dial a Number from Call History” above. The screen display includes DIAL.
- 2 Press **DOWN** until the screen display includes DIAL ALTERNATE.
- 3 Press **LEFT** or **RIGHT** to scroll through the alternate dialing formats (seven digit number, area code + seven digit number, 1 + area code + seven digit number, or 1 + seven digit number). The screen displays the alternate formats on the third line.
- 4 When the format you want to use is displayed, dial the call as described in **Step 3** of “Dial a Number from Call History” above.



Save a Name and Number from Call History to the Directory

- 1 Locate the call record you wish to save (see "Review Records in Call History" beginning on page 46).

⊙ **NOTE:** If a call record does not include a phone number, it cannot be saved to the directory.

- 2 Press **ENTER**. The screen display includes DIAL.
- 3 Press **▼** until the screen display includes COPY TO DIR.
- 4 Press **ENTER** to save the name and number to the directory. The screen displays the entry and add to DIR!.

The screen automatically returns to the call history summary.

⊙ **NOTE:** To exit without saving the number, press **▼** until the display includes RETURN TO LIST, then press **ENTER**.

⊙ **NOTE:** To edit the name or number, press **DIRECTORY** and scroll to the EDIT function.

Save a Number from Call History in a One Touch Location

- 1 Locate the call record you wish to save (see "Review Records in Call History" beginning on page 46).

⊙ **NOTE:** If a call record does not include a phone number, it cannot be saved to a One Touch location.

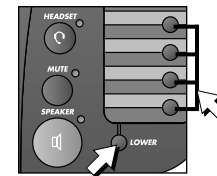
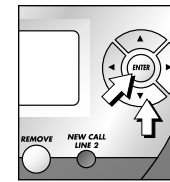

- 2 Press **ENTER**. The screen display includes DIAL.
- 3 Press **▼** until the screen display includes COPY TO 1-TOUCH.
- 4 Press **ENTER** to begin to save the number. The screen displays the entry and PRESS 1-TOUCH.

- 5 Press the One Touch button where you want to save the number

—OR—

Press **LOWER**, then press the One Touch button.

The screen displays the number and Added TO 1TOUCH!. The screen automatically returns to the call history summary.

⊙ **NOTE:** To exit without saving the number, press **▼** until the display includes RETURN TO LIST, then press **ENTER**.

DEFAULT SETTINGS

FEATURE	DEFAULT
Speakerphone Volume	5
Handset Volume	minimum
Headset Volume	minimum
Ringer Volume	3
Auto Speaker	Off
Primary Line	Line 1
Automatic Line Selection	On
Preferred Mode	Speakerphone
Time and Date	12:00 AM, 1/01
Screen Backlight	On
Scroll Rate	Medium
COVM Indicators	Off
Call History	All calls
Repeat Calls	Combined
CID-Call Wait	On
Language	English

GENERAL PRODUCT CARE

To keep your phone working and looking good, follow these guidelines:

- Avoid putting it near heating appliances and devices that generate electrical noise (for example, motors or fluorescent lamps).
- DO NOT expose it to direct sunlight or moisture.
- Avoid dropping the phone and/or other rough treatment.
- Clean with a soft cloth.
- Never use a strong cleaning agent or abrasive powder because this will damage the finish.
- Retain the original packaging in case you need to ship it at a later date.

TECHNICAL SPECIFICATIONS

TECHNICAL SPECIFICATIONS

REN	0.1B
Power Adapter	AC 120V 60Hz 5W AC9V 300mA
FCC #	6YFTE01B992-01
Weight	2.165 lbs.
Dimensions	Length: 8.68 inches Width: 8.58 inches Height: 5.1 inches

IN CASE OF DIFFICULTY

If you have difficulty operating this phone, try the suggestions below. For Customer Service, visit our website at www.telephones.att.com or call **1 800 222-3111**. **Have the serial number, found on the underside of your phone, available when contacting Customer Service. Please retain your receipt as your proof of purchase.**

To purchase accessories or replacement parts contact Customer Service. Visit our website at www.telephones.att.com or call **1 800 222-3111**.

TELEPHONE OPERATION

PROBLEM

No Dial Tone

SOLUTION

- Make sure all plugs are connected properly. Inspect the line cord connections at the modular jack(s) and at the telephone. Also inspect the coiled handset cord connection at both ends.
- Check to make sure the phone is not on hold.
- In the event of a power failure when there is not a charged 9V battery installed, Line 2 cannot be used. Use Line 1 to make your call.
- Unplug the telephone and connect it to another modular jack. If it still does not work and other telephones in your home are working, the problem is with this phone.

PROBLEM

An Error Tone Sounds During Area Code Programming

SOLUTION

If you try to exit area code programming without entering a Home Area Code, you will hear an error tone. Follow the instructions to "Program Home and Local Area Codes" beginning on page 21.

PROBLEM

Call Cannot Be Dialed or is Dialed Slowly

SOLUTION

In the event of a power failure, a charged 9V battery must be installed for the phone to dial out or receive calls normally. If no battery is installed the phone will not ring, but can be used to make a call on Line 1.

TELEPHONE OPERATION

PROBLEM

Difficulty Storing Numbers in Memory

SOLUTION

Make sure you are pressing the correct sequence of buttons for storing numbers in One Touch locations. See ONE TOUCH OPERATION beginning on page 33.

PROBLEM

Telephone Does Not Ring

SOLUTION

- Make sure the ringer volume is not turned off. See “Ringer Volume” on page 27.
- If there are several other telephones on the same line, try disconnecting some of the other telephones. Having too many telephones connected can also create problems such as low ringer volume or impaired sound quality during calls.

PROBLEM

Problems with LINE Lights

SOLUTION

Make sure all plugs are connected properly. Inspect the line cord connections at the modular jack(s) and at the telephone. Also inspect the coiled handset cord connections at both ends.

PROBLEM

A NEW CALL Light Flashes

SOLUTION

Make sure you have reviewed all of the new calls in call history. If you have reviewed the entire call history and the NEW CALL light remains lit but is flashing, your phone may have received a false signal from your Voice Mail service provider. If you have no new Voice Mail messages follow the directions in “Turn NEW CALL Light Off” on page 20.

TELEPHONE OPERATION

PROBLEM

Batt is Displayed

SOLUTION

- Make sure the battery is installed correctly.
- Replace the battery.

PROBLEM

Speakerphone Does Not Work

SOLUTION

If the other person cannot hear you, make sure the MUTE light is off.

PROBLEM

Power Failure is Flashing

SOLUTION

Set the time and date following the directions in “Set Time and Date” on page 17
—OR—
If you subscribe to Caller ID service, the time and date will be reset automatically with the next incoming call.

PROBLEM

Memory Error CID del shown in display

SOLUTION

This display indicates that a rare memory error has occurred in the Call History. To prevent this error from interfering with the normal operation of the telephone, all of the Call History was removed. Your product should now operate normally; no action is required.

INDEX

- ▼ 3, 12, 13, 37
- ◀ 3, 12, 13, 37
- ☎ 12
- ▶ 3, 12, 13, 37
- ▲ 3, 12, 13, 37
- ☎ 12
- 34

A

- ADD ENTRY 38
- All Calls 22
- ALS ON/OFF 15
- alternate dialing formats 49
- Auto Redial 29
 - (AUTO REDIAL)** 28, 29, 34, 39
- Auto Speaker 14, 35, 36
- automatic line selection 15, 25, 26, 29

B

- Batt 5, 32, 57
- battery 5, 32, 55
- battery cover 5
- buzz 4

C

- Call Cannot Be Dialed or is Dialed Slowly 55
- call history 21–23, 44, 46–50, 56
 - (CALL HISTORY)** 46, 47
- call information 45, 47
- call record 48, 50
- call record number 47
- Call Waiting 31
- Call Waiting call 24, 43, 45

58

- Caller ID 3, 37, 43
- Caller ID information 5, 43, 44
- Caller ID service 17, 44
- Caller ID with Call Waiting 3, 24, 43, 45
- Caller Identification 3
- Caller Identification service 43
- Central Office Voice Mail 3
- CID-CALL WAIT 24
- coiled handset cord 2, 7, 9
- Combined 23
 - (CONFERENCE)** 31, 32
- conference call 31
- confirmation tone 4, 12
- COVM 3
- COVM 19
- COVM indicator 19

D

- data port 11
- date 17, 44, 47
- desk wedge 2, 5, 6, 9
- DIAL ALTERNATE 49
- dial pad keys 38
- dial tone 8, 25, 28, 31, 36
- Difficulty Storing Numbers in Memory 56
- directory 37–40, 42, 50
 - (DIRECTORY)** 37, 38, 40, 41
- directory card 33
- directory entry 40–42
- DIRECTORY FULL! 37
- Display Dial 28
- display language 24

E

- English 24
 - (ENTER)** 3, 12, 13, 34, 35, 37, 38
- Enter name 38
- Enter Number 34
- error tone 4, 11, 12, 17, 26, 34, 55
- Espanol 24

F

- F 35
- fax machine 11
- feature setup 12, 13
 - (FLASH)** 31, 45
- flash signal 35
- Francais 24

H

- hands-free 11
- handset 25, 26, 28, 29, 36, 49
- handset jack 7, 9
- handset tab 9
- headset 11, 16, 25, 26, 28, 30, 36, 42, 49
 - (HEADSET)** 26, 28, 29, 36, 42, 49
- headset jack 11, 26
- HEADSET light 26
- hold 27, 30
 - (HOLD)** 30–32
- Home Area Code 3, 21, 43, 55

L

- LCD backlight 18
- light off 20
- LINE button 25, 27–32, 42, 49
- line cord 2, 6, 7, 10
- Local Area Code 3

- Local Area Codes 21, 43
 - (LOWER)** 33, 34, 36
- LOWER MEMORY 34, 35

M

- memory 12
- Memory Loss Protection 5
- menu 13, 37
- menus 12
- messages 46
- mode 16, 25, 42, 49
- modem 11
- mute 31
 - (MUTE)** 31
- MUTE light 31, 57

N

- navigation buttons 3, 12, 37
- NEW CALL light 19, 20, 46
- NEW CALL Light Flashes 56
- No Calls 22
- No Dial Tone 55
- No Entries FOR "X" 40

O

- One Touch button 14, 33–36
- One Touch call 14
- One Touch entries 33
- One Touch entry 35
- One Touch location 34–36
- One Touch locations 33, 56
- One Touch number 14
- Only 24 digits are allowed 34

59

P

P 35
 pause 35
 power adapter 2, 8, 11
 power cord 8, 9
 Power Failure 57
 power failure 5, 55
 preferred mode 16
 Primary Line 3, 14, 25, 27–29, 42
 Problems with LINE Lights 56
 programming 12

R

red LINE light 30
 redial memory 28
 REMOVE 42, 48
 RETURN TO LIST 49, 50
 ringer volume 27, 56

S

sample ring 27
 screen 18
 screen display 12
 scroll button 13
 scroll rate 18
 Separate 23
 speak privately 32
 SPEAKER 25, 28, 29, 36, 42, 49
 SPEAKER light 25
 speakerphone 16, 25, 26, 28, 30,
 36, 42, 49
 Speakerphone Does Not Work 57
 switch lines 30
 switchhook 31

60**T**

Telephone Does Not Ring 56
 three ascending tones 4
 three beeps 4, 27
 Three-Way Calling 31
 time 17, 44, 47
 timer 27

V

Voice Mail 19, 46, 56
 volume 27
 VOLUME ▲ 27
 VOLUME ▼ 27

W

W 35
 wait 39
 WAIT 35, 39
 Waiting for caller
 information 44
 wall jack 6, 7, 10