

## Economical and Vandal Resistant Hot-Line Phones



**K-1900-6**



**K-1900W-2 ASH**



**K-1900D-2 ASH**



**K-1900D-2**

The **K-1900** Series of Hot-Line phones are programmable to dial a 1-32 digit telephone number each time the phone's handset is lifted. The products may be programmed to Touch Tone or pulse dial and will not dial on incoming calls.

The **K-1900** Series phones are available in a desk or wall chassis, as well as in a vandal resistant panel phone configuration. A network insert dialer is also available, to convert standard phones into hot-line phones.



**K-1900-7**

**K-1900W-2**

## Features

- Telephone line powered
- Hearing aid compatible amplified handsets
- Rotary handset volume control
- 1 - 32 digit programmable speed dial number
- Touch Tone and 10/20 pps pulse dialing
- Non-volatile E<sup>2</sup> memory (no batteries required)
- Restricts fraudulent calls from hand held dialers
- **K-1900D/W-2** available in red or ash
- Optional **Q170600** ringer (Fax Back Doc 845)
- Operates on a C.O. line or analog PABX/KSU extensions
- Ring detection (will not dial on incoming calls)
- Programmable security code to enter programming mode
- Touch Tone programmable
- **K-1900-6** fits standard 500, 554, 2500 and 2554 set phones

## Applications

- Catalog sales
- Information kiosks in malls
- Courtesy and customer service phones
- Automated tellers
- Hot-line reservation phones
- Replace leased Ringdown circuits
- Security and emergency phones (pools, etc.)

**Phone... 715.386.8861**

**info@vikingelectronics.com**

**http://www.vikingelectronics.com**

## Specifications

**Power:** Telephone line powered (20V DC/18mA minimum)  
**Environmental:** 0°C to 32°C (32°F to 90°F) with 5% to 95% non-condensing humidity  
**Dimensions:** (see page 2)  
**Dialing Speed:** Normal - 120ms tones/10 pps, Fast - 50ms tones/20 pps

## IF YOU HAVE A PROBLEM WITH A VIKING PRODUCT, PLEASE CONTACT: VIKING TECHNICAL SUPPORT AT (715) 386-8666

Our Technical Support Department is available for assistance Monday 8am - 4pm and Tuesday through Friday 8am - 5pm central time. So that we can give you better service, before you call please:

1. Know the model number, the serial number and what software version you have (see serial label).
2. Have your Technical Practice in front of you.
3. It is best if you are on site.

### RETURNING PRODUCT FOR REPAIR

The following procedure is for equipment that needs repair:

1. Customer must contact Viking's Technical Support Department at 715-386-8666 to obtain a Return Authorization (RA) number. The customer MUST have a complete description of the problem, with all pertinent information regarding the defect, such as options set, conditions, symptoms, methods to duplicate problem, frequency of failure, etc.
2. Packing: Return equipment in original box or in proper packing so that damage will not occur while in transit. Static sensitive equipment such as a circuit board should be in an anti-static bag, sandwiched between foam and individually boxed. All equipment should be wrapped to avoid packing material lodging in or sticking to the equipment. Include ALL parts of the equipment. C.O.D. or freight collect shipments cannot be accepted. Ship cartons prepaid to: **Viking Electronics, 1531 Industrial Street, Hudson, WI 54016**
3. Return shipping address: Be sure to include your return shipping address inside the box. We cannot ship to a PO Box.
4. RA number on carton: In large printing, write the R.A. number on the outside of each carton being returned.

### RETURNING PRODUCT FOR EXCHANGE

The following procedure is for equipment that has failed out-of-box (within 10 days of purchase):

1. Customer must contact Viking's Technical Support at 715-386-8666 to determine possible causes for the problem. The customer MUST be able to step through recommended tests for diagnosis.
2. If the Technical Support Product Specialist determines that the equipment is defective based on the customer's input and troubleshooting, a Return Authorization (R.A.) number will be issued. This number is valid for fourteen (14) calendar days from the date of issue.
3. After obtaining the R.A. number, return the approved equipment to your distributor, referencing the R.A. number. Your distributor will then replace the product over the counter at no charge. The distributor will then return the product to Viking using the same R.A. number.
4. **The distributor will NOT exchange this product without first obtaining the R.A. number from you. If you haven't followed the steps listed in 1, 2 and 3, be aware that you will have to pay a restocking charge.**

### WARRANTY

Viking warrants its products to be free from defects in the workmanship or materials, under normal use and service, for a period of one year from the date of purchase from any authorized Viking distributor or 18 months from the date manufactured, whichever ever is greater. If at any time during the warranty period, the product is deemed defective or malfunctions, return the product to Viking Electronics, Inc., 1531 Industrial Street, Hudson, WI., 54016. Customer must contact Viking's Technical Support Department at 715-386-8666 to obtain a Return Authorization (R.A.) number.

This warranty does not cover any damage to the product due to lightning, over voltage, under voltage, accident, misuse, abuse, negligence or any damage caused by use of the product by the purchaser or others.

Viking's sole responsibility shall be to repair or replace (at Viking's option) the material within the terms stated above. VIKING SHALL NOT BE LIABLE FOR ANY LOSS OR DAMAGE OF ANY KIND INCLUDING INCIDENTAL OR CONSEQUENTIAL DAMAGES RESULTING DIRECTLY OR INDIRECTLY FROM ANY BREACH OF ANY WARRANTY EXPRESSED OR IMPLIED, OR FOR ANY OTHER FAILURE OF THIS PRODUCT. Some states do not allow the exclusion or limitation of incidental or consequential damages, so this limitation may not apply to you.

THIS WARRANTY IS IN LIEU OF ALL OTHER WARRANTIES, EXPRESSED OR IMPLIED, INCLUDING THE WARRANTIES OF MERCHANTABILITY AND FITNESS FOR A PARTICULAR PURPOSE, WHICH ARE HEREBY EXCLUDED BEYOND THE ONE YEAR DURATION OF THIS WARRANTY. Some states do not allow limitation on how long an implied warranty lasts, so the above limitation may not apply to you.

### FCC REQUIREMENTS

This equipment complies with Part 68 of the FCC rules. Located on the equipment is a label that contains, among other information, the FCC registration number and ringer equivalence number (REN). If requested, this information must be provided to the telephone company.

The REN is used to determine the quantity of devices which may be connected to the telephone line. Excessive REN's on the telephone line may result in the devices not ringing in response to an incoming call. In most, but not all areas, the sum of the REN's should not exceed five (5.0). To be certain of the number of devices that may be connected to the line, as determined by the total REN's, contact the telephone company to determine the maximum REN for the calling area.

This equipment cannot be used on the telephone company-provided coin service. Connection to Party Line Service is subject to State Tariffs.

If this equipment causes harm to the telephone network, the telephone company will notify you in advance that temporary discontinuance of service may be required. If advance notice isn't practical, the telephone company will notify the customer as soon as possible. Also, you will be advised of your right to file a complaint with the FCC if you believe it is necessary.

The telephone company may make changes in its facilities, equipment, operations, or procedures that could affect the operation of the equipment. If this happens, the telephone company will provide advance notice in order for you to make the necessary modifications in order to maintain uninterrupted service.

If trouble is experienced with this equipment, please contact: **Viking Electronics, Inc., 1531 Industrial Street, Hudson, WI 54016 (715) 386-8666**

If the trouble is causing harm to the telephone network, the telephone company may request you to remove the equipment from the network until the problem is resolved.

The K-1900D-2 uses USOC jack RJ11C, K-1900W-2 and K-1900-7 use USOC jack RJ11W.

It is recommended that the customer install an AC surge arrester in the AC outlet to which this device is connected. This is to avoid damaging the equipment caused by local lightning strikes and other electrical surges.

This equipment is Hearing-Aid Compatible (HAC).

The telephone Consumer Protection Act of 1991 makes it unlawful for any person to use a computer or other electronic device, including fax machines, to send any message unless such message clearly contains in a margin at the top or bottom of each transmitted page or on the first page of the transmission, the date and time it is sent and an identification of the business or other entity, or other individual sending the message and the telephone number of the sending machine or such business, other entity, or individual. (The telephone number provided may not be a 900 number or any other number for which charges exceed local or long-distance transmission charges.)

### PART 15 LIMITATIONS

This equipment has been tested and found to comply with the limits for a Class A digital device, pursuant to Part 15 of the FCC Rules. These limits are designed to provide reasonable protection against harmful interference when the equipment is operated in a commercial environment. This equipment generates, uses, and can radiate radio frequency energy and, if not installed and used in accordance with the instruction manual, may cause harmful interference to radio communications. Operation of this equipment in a residential area is likely to cause harmful interference in which case the user will be required to correct the interference at his own expense.

## Specifications and Installation

Viking offers three variations of hot-line phones and one network dialer. Below are model numbers and descriptions of the Hot Line phones Viking offers. Each model is designed for specific applications, including varying mounting capabilities and levels of vandal protection. The following sections describe the product model numbers, their applications, installation and specifications.

**!** **Important:** Use a minimum wire gauge of 26 when connecting the K-1900 phone to the public switched network.

### K-1900D-2 Hot Line Desk Phone

To install the **K-1900D-2** insert the RJ11 plug into a standard RJ11 jack as shown to the right.

**Dimensions:** 230mm x 210mm x 120mm (9.0" x 8.25" x 4.75")

**Shipping Weight:** 1.36 Kg (3 lbs)

**Connections:** RJ11

**Colors:** Red or Ash

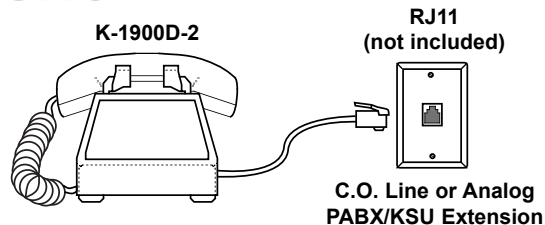

### K-1900W-2 Hot Line Wall Phone

To install the **K-1900W-2** line up the pins of the RJ11W jack with the slots on the back of the phone, insert and press down as shown to the right.

**Dimensions:** 102mm x 178mm x 229mm (4.0" x 7.0" x 9.0")

**Shipping Weight:** 1.36 Kg (3 lbs)

**Connections:** RJ11W

**Colors:** Red or Ash

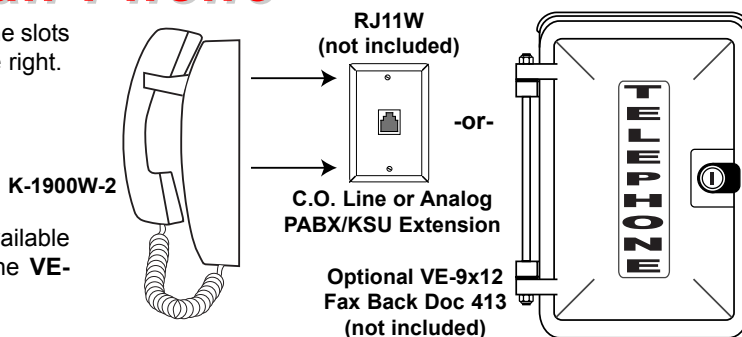

Optional **VE-9x12** Weatherproof Housing for the **K-1900W-2**, available in emergency red or safety yellow. For more information on the **VE-9x12**, retrieve **Fax Back Document 413**.

# K-1900-6 Hot Line Dialer Network

The **K-1900-6** Hot-Line Dialer Network can be used with any carbon microphone handset and a DPST (Double Pole Single Throw) hook switch or typical 500, 554, 2500 and 2554 phones. Attach wires as shown to the right. An electronic ringer may be used if inbound call capability is required.

**Required Handset Type:** Carbon microphone  
**Required Hookswitch:** One normally open contact and one normally closed contact  
**Dimensions:** 88.9mm x 68.6mm x 33mm (3.5" x 2.7" x 1.3")  
**Shipping Weight:** 0.45 Kg (1.0 lb)  
**Connections:** Miniature spade receptacles  
**Compatible Phones:** 500, 554, 2500 and 2554

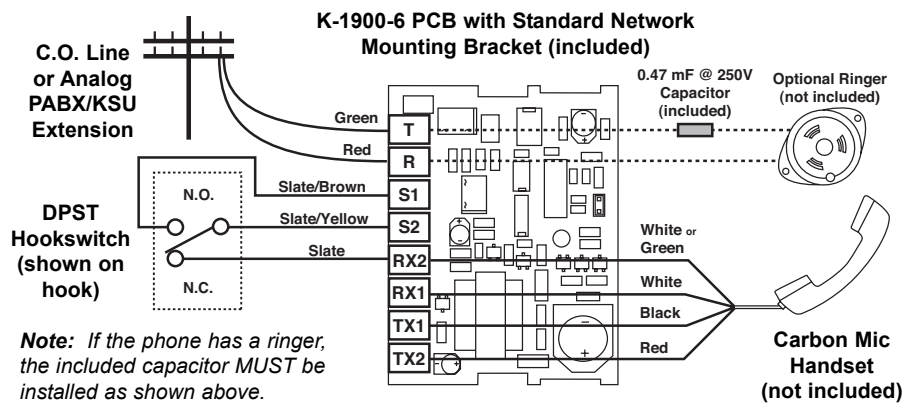

# K-1900-7 Hot Line Panel Phone

To install the **K-1900-7** vandal resistant hot line panel phone, attach the panel to an existing double gang box (with minimum dimensions shown right) using the provided screws. Insert a cord into the RJ11 jack on the back of the **K-1900-7**. **Note:** Four extra screws and nuts are provided to fill the unused mounting holes.

**Dimensions:** 127mm x 254mm x 102mm (5" x 10" x 4")  
**Shipping Weight:** 1.36 Kg (3 lbs)  
**Connections:** RJ-11  
**Panel Material:** .125 inch stainless steel  
**Mounting:** Flush mount to the included double gang box. Optional **VE-5x10** weather resistant surface mount box and **VE-9x20** weatherproof box for outdoor applications available.

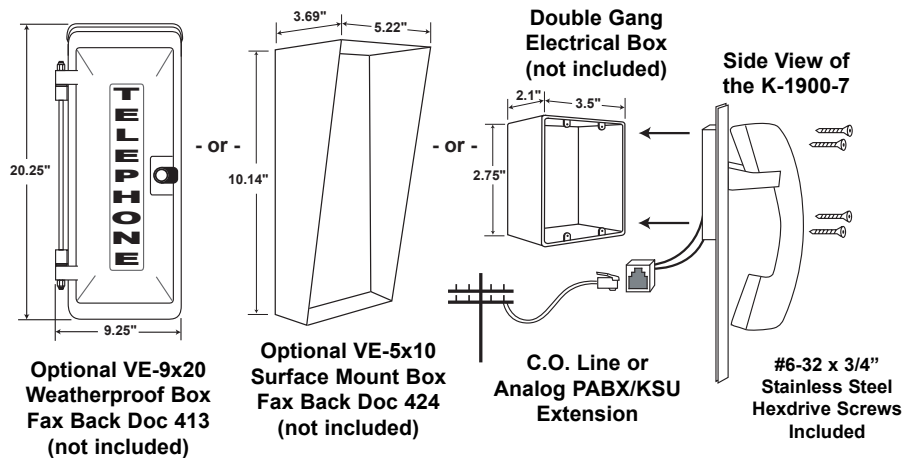

# Programming

While in the programming mode, two beeps indicate a valid programming entry. An invalid entry will be indicated with three beeps. To exit programming, simply hang-up the **K-1900** Series phone.

## A. Accessing the Programming Mode

### 1. Using the Security Code

<b>Step 1.</b>	Connect the <b>K-1900</b> Series device to an analog C.O. line, or an analog PABX/KSU station.
<b>Step 2.</b>	From a Touch Tone phone, call into the <b>K-1900</b> Series phone.
<b>Step 3.</b>	Listen for at least one ringback in the calling phone and then take the <b>K-1900</b> Series phone off-hook (answer the phone).
<b>Step 4.</b>	From the Touch Tone phone, enter your six digit security code (factory set to <b>845464</b> - see section <b>E</b> ).
<b>Step 5.</b>	A double beep indicates the <b>K-1900</b> Series phone is in the programming mode (see sections <b>B-G</b> ). If six digits are entered and no beeps are heard, an incorrect security code has been entered. Repeat steps <b>2-5</b> or follow directions in <b>2. Without a Security Code</b> below.

### 2. Without a Security Code (If You Have Forgotten or Lost the Security Code)

<b>Step 1.</b>	Remove <b>JP1</b> (as shown to the right). For the <b>K-1900W-2</b> and <b>K-1900D-2</b> , the plastic cover must be removed to expose the circuit board.
<b>Step 2.</b>	Connect the <b>K-1900</b> Series device to a C.O. line, analog PABX/KSU station or to a <b>DLE-200B</b> Line Simulator.
<b>Step 3.</b>	From a Touch Tone phone, call into the <b>K-1900</b> Series phone.
<b>Step 4.</b>	Listen for at least one ringback in the calling phone and then take the <b>K-1900</b> Series phone off-hook (answer the phone).
<b>Step 5.</b>	A double beep indicates the <b>K-1900</b> Series phone is in the programming mode (see <b>Programming</b> sections <b>B-G</b> ).
<b>Step 6.</b>	When programming is finished, replace <b>JP1</b> and replace cover on phone.

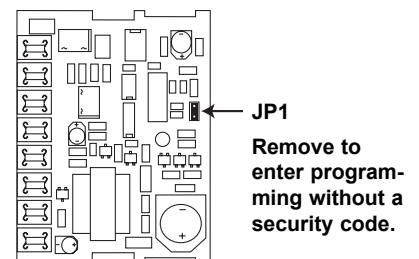

**Note:** **JP1** **MUST** be in place for normal operation.

## B. Quick Programming Guide

	Enter Digits	then	Memory Location
Speed dial number (see section C) 1-32 digits or pauses .....	phone number	then	#0
Security Code, factory set to <b>845464</b> (see section E) .....	6 digits	then	#9
To add a * anywhere in the dialing string .....	**		
To add a # anywhere in the dialing string .....	*#		
To set dialing speed to normal - 120ms tones/10 pps (factory setting) .....	*1		
To set dialing speed to fast - 50ms tones/20pps .....	*2		
To restrict Touch Tone user dialing (factory setting) .....	*3		
To enable Touch Tone user dialing .....	*4		
Toggles between pulse and Touch Tone dialing (see section C) .....	*6		
To add a 4 second pause anywhere in the dialing string (see section C) .....	*7		
To add a 1 second pause anywhere in the dialing string .....	*8		
To clear all programming and change back to factory settings .....	###		

## C. Programming Examples

To Program the K-1900 Series Phone to...	Step 1 - See section A	Step 2 - Enter Digits
...to Touch Tone dial 555-1234	Enter Programming	5551234 + #0
...to pulse dial 555-1234 followed by a Touch Tone 9	Enter Programming	*6 5551234 *6 9 + #0
...to dial a 9, a 4 second pause and then 555-1234	Enter Programming	9 *7 5551234 + #0
...to set the dialing speed to fast	Enter Programming	*2
...to enable unlimited user dialing after the phone has speed dialed	Enter Programming	*4
...to clear the speed dial number or disable speed dialing	Enter Programming	#0

## D. Touch Tone and Pulse Dial Speeds

The **K-1900** Series phone can be programmed to dial at normal or fast dialing speeds. While in the programming mode, enter **\*1** for normal dialing speed - 120ms on/off Touch Tones or 10 pps pulse dialing. Enter **\*2** for fast dialing speed - 50ms on/off Touch Tones or 20 pps pulse dialing.

## E. Security Code

A six digit security code is required to access the programming mode. The factory set security code is **845464** (V-I-K-I-N-G). It is recommended that you change the security code to a personal 6 digit (0-9) number in memory position **#9** while in the programming mode. **Note:** The security code must be six digits in length and cannot contain a \* or #.

## F. Touch Tone or Pulse Dialing

The **K-1900** Series phones are factory set to automatically dial using Touch Tones. A **\*6** entered in the speed dial number will toggle the dialing mode between Touch Tone and pulse (see section C).

**Note:** You can NOT program a \* and # to be pulse dialed.

## G. Touch Tone User Dialing Restriction (factory enabled)

The **K-1900** Series phones is factory set to restrict fraudulent calls from hand held pocket dialers. After speed dialing, the **K-1900** Series phones will restrict (hang up) when they detect any Touch Tone that they did not generate. To restrict user dialing, enter **\*3** while in the programming mode. To enable user dialing, enter **\*4** while in the programming mode.

# Adding an Internal Ringer

An optional **Q170600** internal ringer is available. For more information, retrieve **Fax Back Document 834**.

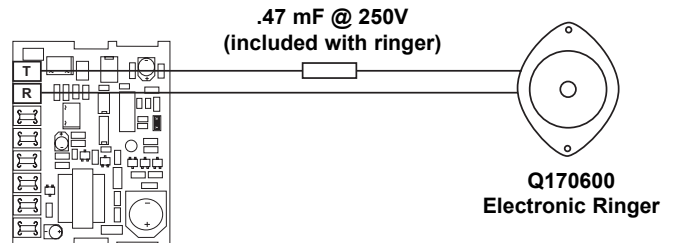

**Product Support Line...715.386.8666**

**Fax Back Line...715.386.4345**

Due to the dynamic nature of the product design, the information contained in this document is subject to change without notice. Viking Electronics, and its affiliates and/or subsidiaries assume no responsibility for errors and omissions contained in this information. Revisions of this document or new editions of it may be issued to incorporate such changes.